

Breathe in to Boost Performance !

press releases

TRAINING THE INSPIRATORY MUSCLES CAN IMPROVE SWIMMING PERFORMANCE

Competitive swimming is one of the ultimate challenges for breathing. Swimmers competing in 100m events breathe very little. For example, they may breathe as little as eight times during a race that lasts almost a minute - taking one breath in the first 25m, three in the second, three in the third and one in the final 25m!



‘When they do breathe, swimmers have to inhale as much as possible in the shortest time possible so that they can return their bodies to the optimal position for generating propulsive force’, explains sports scientist and respiratory physiologist, Dr Alison McConnell. ‘This creates an enormous strain on the inspiratory muscles (muscles used to inhale) and it is no surprise to find that swimmers experience significant fatigue of these muscles’.

McConnell continues, ‘**Our research has shown that swimming just 200m at 90-95% of race pace is sufficient to induce a significant level of breathing fatigue (a 20% fall in strength) in competitive swimmers.** The situation is worsened by the fact that when you are lying horizontal in the water, your breathing muscles are up to 16% weaker than when you’re upright - this means that they are less able to generate the forces needed to breathe in quickly. I was very surprised that such a profound fatigue occurred after such a short time (2 minutes 40 seconds), and when I calculated the number of breaths that the swimmers took during the 200m, I was even more surprised - it was only 70 breaths. This conveys a very strong message to me that swimmers are at great risk of developing breathing fatigue’.

But why should this matter? ‘Breathing sends very strong signals to the parts of the brain that tell you how hard you are working. It’s well known that when muscles fatigue, the sense of effort associated with using them increases, and this, in turn, makes your overall sense of effort greater. Furthermore, research has shown that fatigue of the breathing muscles reduces blood flow to the other exercising muscles and this can slow you down by reducing the flow of oxygen to those muscles’, Alison explains.

So what can be done? ‘Our research on rowers and cyclists has shown that if you make the inspiratory muscles stronger by training them, you reduce the extent of the fatigue that is induced during heavy exercise - in fact it almost disappears completely. This research also showed that the performance of rowers and swimmers increases by up to 3.5%!

Alison McConnell is an expert on breathing during exercise and, whilst based at Birmingham University, her research team developed a drug free training device that specifically targets the breathing muscles -

POWERbreathe®. You breathe through the portable, hand-held device for 30 repetitions (this takes 3 minutes) twice daily, and the strength of your inspiratory muscles increases by around 30-50%. McConnell’s research team have also proved the ergogenic effect of the POWERbreathe in other sports, including cycling.

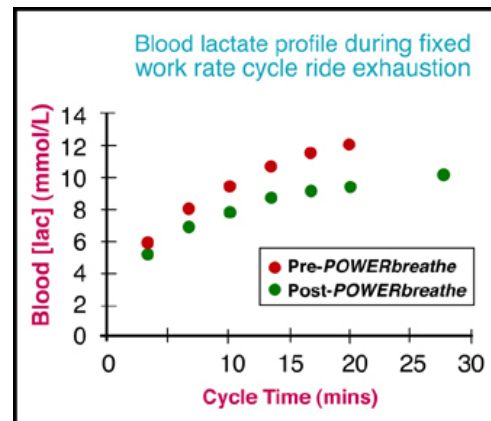
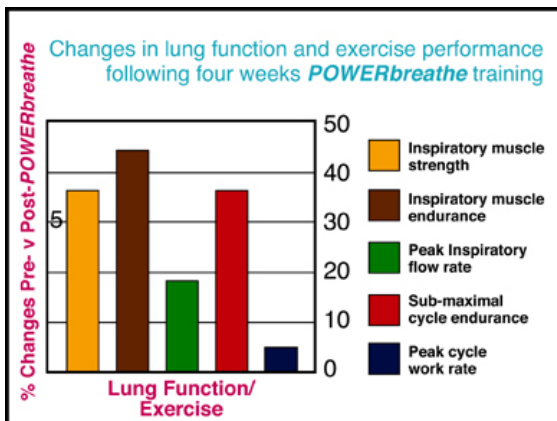
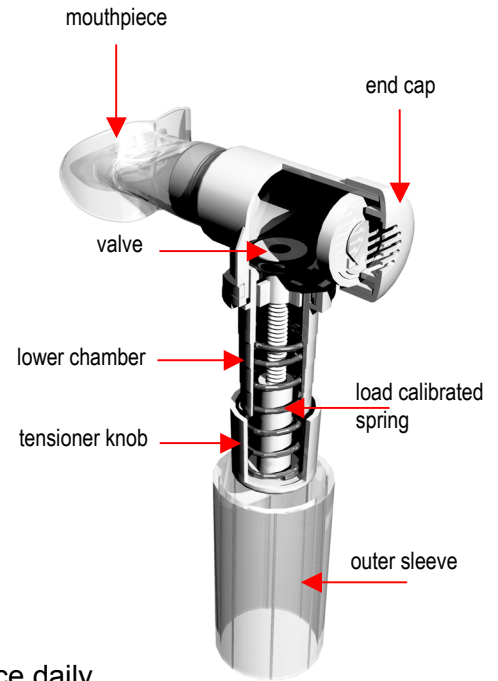

The product uses the basic principles of resistance training. Just as you might use weights to strengthen your arm muscles, breathing in through POWERbreathe® for a few minutes twice daily, makes your inspiratory muscles (the muscles we use to breathe in) work harder - thereby increasing their strength and endurance.

So if swimming just a few lengths leaves you breathless, or you’re a competitive swimmer looking for a legal edge, POWERbreathe® may be just what you need.

For local stockists please call CHP on 01926 816177.
 For mail order please call Bodycare on 01926 816155.
 For further press information, please contact Philippa Rawlinson on 01926 816118,
 or email philippa.rawlinson@lsi.co.uk