

# Breathe in to Boost Performance !

press releases

## TRAINING THE INSPIRATORY MUSCLES CAN IMPROVE CYCLING PERFORMANCE

One of the many distinguishing features of Miguel Indurain was the size of his lungs. His useable lung volume (vital capacity) was amongst the highest ever measured at a whopping 7.1 litres. To put this into perspective the average man in the street comes in at a puny 5.2 litres, whilst the lungs of most 'athletic' women seldom exceed 4.5 litres.



The hunched position adopted during cycling is a double-edged sword for the cyclist. On the one hand, it enhances aerodynamics, but on the other, it can create breathing problems.

'When you are hunched forward, the contents of your abdomen (mainly your liver and gut) become compressed and pushed up against your main breathing muscle, the diaphragm. This restricts its normal movement and can make breathing feel much harder', explains sports scientist and respiratory physiologist, Dr Alison McConnell, 'On the plus side, the upper body is supported and this means that the other breathing muscles can 'concentrate' on breathing, not stabilising the upper body as they do when you are running'.

**Its now well accepted that the work of breathing during exercise can be high enough to cause the breathing muscles to fatigue.** 'Our research has shown that cycling as little as 20km at race pace induces significant fatigue of the inspiratory muscles (the muscles used to inhale)', explains McConnell. Whilst based at Birmingham University, McConnell 's research group pioneered a technique known as **inspiratory muscle training** and showed that **it reduces breathing fatigue and improves cycling time trail performance by a staggering 4.6% (that's equivalent to slicing around 2 minutes off your 40k PB)**! 'We tested some very well trained athletes in that particular study and I was astonished by the huge magnitude of the ergogenic effect that we observed after just six weeks of inspiratory muscle training'.

By now you're probably wondering what sort of agonising respiratory gymnastics are required to get this sort of ergogenic effect. Alison McConnell's team of scientists developed a very simple technique for training the inspiratory muscles – they called it '**dumb bells for your diaphragm**'. A special, **drug-free** training device was developed - **POWERbreathe®** - that enables athletes to effectively lift weights with their inspiratory muscles.

You breathe through the portable, hand-held device for 30 repetitions (this takes three mins) twice daily, and the strength of your inspiratory muscles increases by around 30-50%. McConnell's research team have also proved the ergogenic effect of the POWERbreathe in other sports, including rowing.

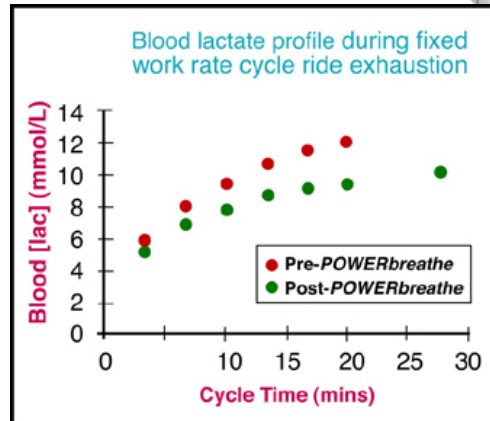
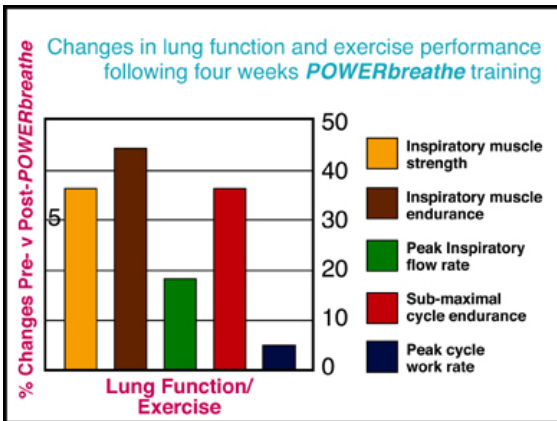
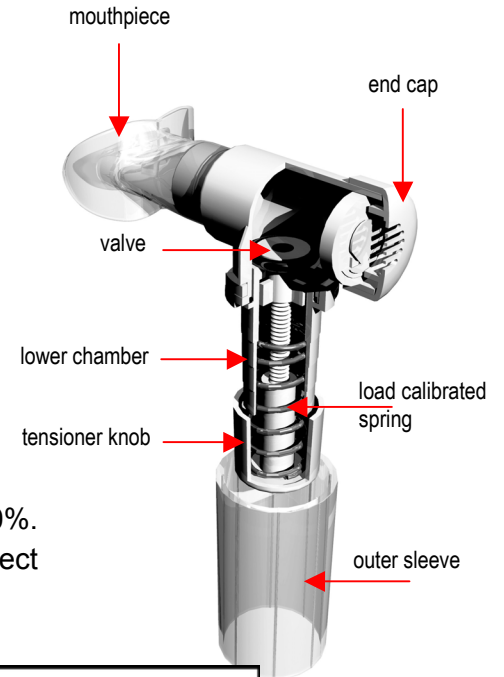

So in a sport dogged by controversy and hazardous illegal shortcuts to better performance (blood doping and EPO), could it be that something as simple as breathing has been completely overlooked as a limiting factor to performance? 'I think that breathing is the final 'unturned stone' in the quest for total athlete preparation; sports scientists, dieticians and coaches hone every detail of the athlete's mental and physical preparation, except their breathing. I certainly think it offers a better guarantee of improvement than altitude training', explains McConnell.

***You may not be able to match Indurain's lung volume, but after using POWERbreathe® you should certainly be able to give his breathing muscles a run for their money, and save a few quid on that altitude training camp in the Alps.***

For local stockists please call CHP on 01926 816177.  
 For mail order please call Bodycare on 01926 816155.  
 For further press information, please contact Philippa Rawlinson on 01926 816118,  
 or email philippa.rawlinson@lsi.co.uk